

Vilter Manufacturing Corporation
5555 South Packard Avenue
PO Box 8904
Cudahy, Wisconsin 53110-8904
Phone: 414.744.0111 Fax: 414.744.3493
www.vilter.com

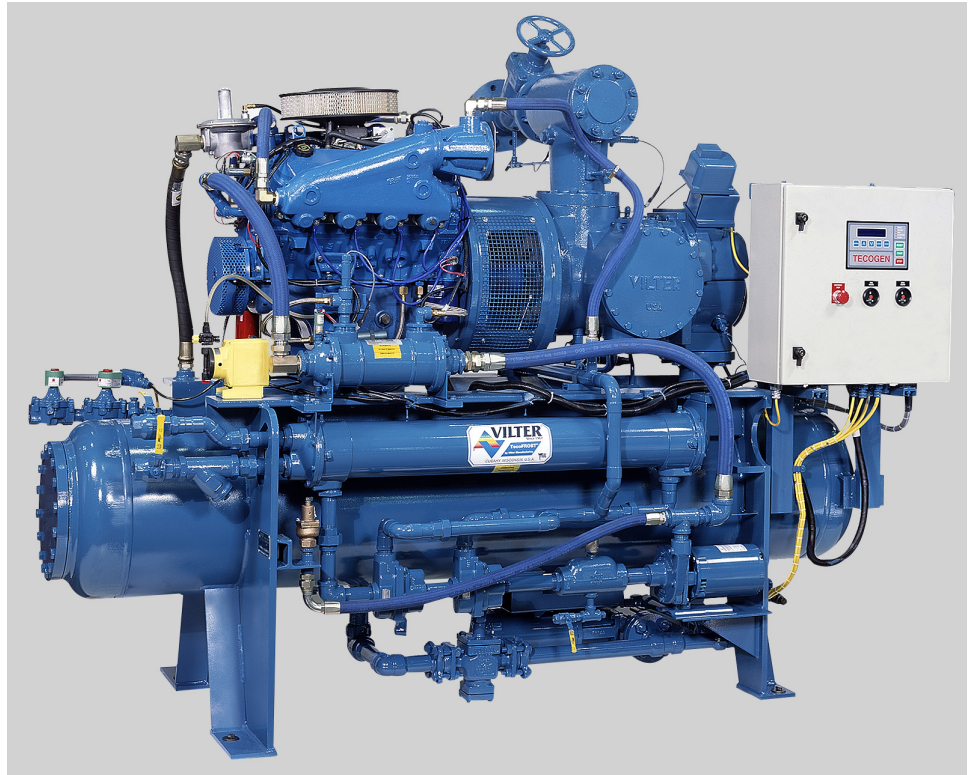

Natural Gas Engine Driven Refrigeration



TecoFROST™

by Vilter/Tecogen

SUCCESSFUL APPLICATIONS INCLUDE:

- | | | |
|--------------------------|------------------|------------------------|
| ⇒ Cold Food Storage | ... Breweries | ⇒ Ice Rinks |
| ⇒ Food Processors | ... Dairies | ⇒ Industrial Processes |
| ... Bakeries | ... Wineries | ... Pharmaceutical |
| ... Beef, Pork & Poultry | ⇒ Ice Production | ... Petrochemical |

MAXIMUM OPERATING SAVINGS

In many regions, the total cost of meeting refrigeration load by natural gas is substantially less than the cost of using electricity. The variable speed operation of the TecoDrive natural gas engine used on the TecoFROST optimizes energy use by closely following the load profile. This variable speed capability provides additional benefits of longer intervals between required maintenance on both the engine and compressor. This annual operating savings is significant and yields a rapid payback.

AVOID HIGH DEMAND AND ENERGY CHARGES

Refrigeration plants have extremely large electrical demand and usage loads. In many applications this load peaks in the daytime and summer, the same periods when electricity is the most expensive and natural gas supply is the most abundant. By reducing the refrigeration plant electric demand and usage during these periods, owners can save significantly in their total energy costs through the entire year.

UTILIZE ENGINE AND EXHAUST WASTE HEAT FOR HOT WATER OR PROCESS NEEDS

Maximum savings can be realized by utilizing the heat generated by the engine jacket and exhaust gas. Recovered heat can be used for space heating, domestic hot water, boiler feed water preheating, or process applications. Nearly one-half of the engine fuel consumption can be recovered through this waste heat and is available up to 225°F.

[MAXIMUM ENERGY SAVINGS]

Typical Savings Example:*

Design Conditions:

Refrigeration Peak Load: 232.4 tons
 Annual Hours of Operation : 5,000
 Avg. Saturated Suction Temp: 20°F
 Avg. Saturated Discharge Temp.: 95°F
 Max SDT (for peak load calc): 95°F

Heat Recovery:

Useful Thermal Energy: 728,110 Btu/Hr
 Summer Boiler Efficiency: 75%

Natural Gas Utility Rates:

Cooling Rate: \$0.50/therm
 Boiler Rate: \$0.50/therm

Electric Utility Rates:**

Summer Demand: \$17/kW
 Winter Demand: \$5.20/kW
 Energy: \$0.090/kWH

* (2) TecoFROST Model VSM 501 used for analysis.
 ** 2002 California Electric Rates

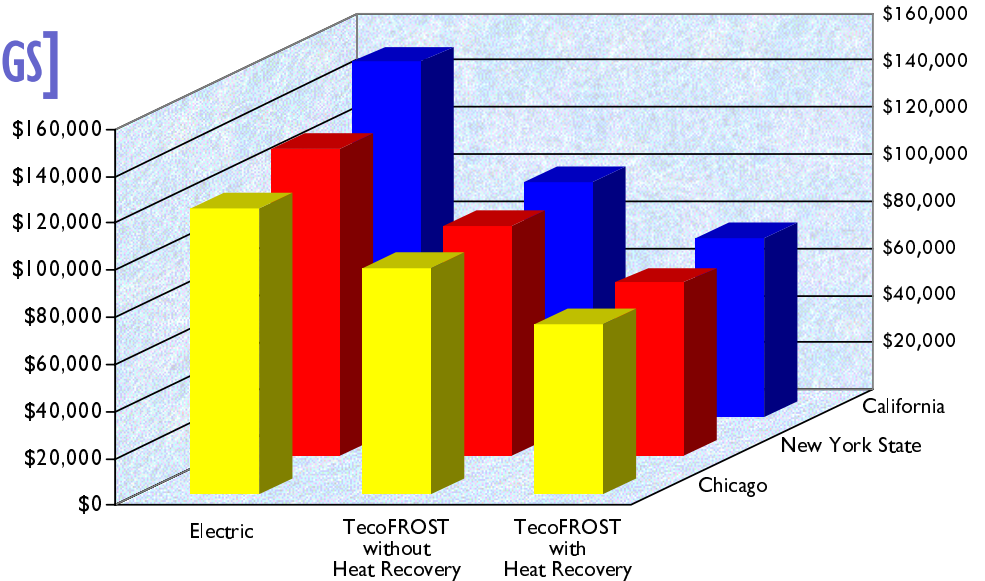

ANNUAL ENERGY COSTS: Electric vs. TecoFROST

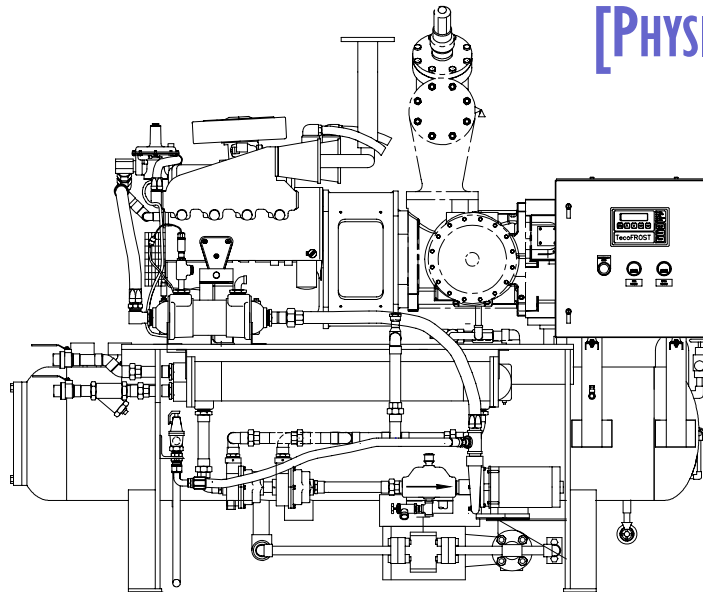
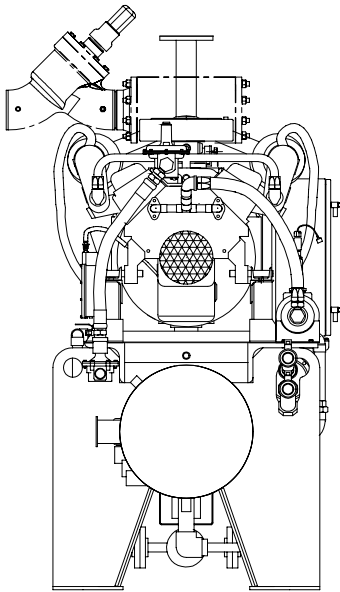

[PHYSICAL DIMENSIONS]

Length (L): 8'9"
Width (W): 4'3"
Height: 7'4"
Weight: 4,000 lbs

Dimension Notes:

- All dimensions are approximate and subject to change; consult factory for most current installation drawings.
- Minimum Service Clearances:
 - 3 feet on all sides for routine service.
 - 2 feet above unit for engine and compressor removal.

[PERFORMANCE DATA]

VSM 501 RATINGS @ 3000 RPM FOR R-717

SST(°F)	psig	SDT(Deg F)/psig															
		75/125.8				85/151.7				95/181.1				105/214.2			
		TR	BHP	Fuel	EHR	TR	BHP	Fuel	EHR	TR	BHP	Fuel	EHR	TR	BHP	Fuel	EHR
-40	8.7*	32	86	880	294	30	97	960	315	27	108	1040	335	25	121	1136	360
-30	1.6*	45	94	938	309	42	107	1033	334	40	119	1122	356	37	134	1233	385
-20	3.6	61	100	982	320	58	115	1092	349	55	130	1203	377	52	146	1322	408
-10	9.0	80	110	1055	339	77	123	1151	364	74	139	1270	394	70	157	1405	429
0	15.7	104	119	1122	356	100	133	1225	383	96	148	1337	411				
10	23.8	133	124	1159	366	128	142	1293	400	(see Note 5)				(see Note 5)			
20	33.5	168	128	1188	373	162	147	1330	410	(see Note 5)				(see Note 5)			
30	45.0	210	126	1173	370	203	151	1360	417	(see Note 5)				(see Note 5)			
40	58.6	261	118	1114	354	252	147	1330	410	(see Note 5)				(see Note 5)			

*inches of mercury below one atmosphere

Performance Notes:

- R-22 ratings available on request.
- Ratings based on external compressor oil cooling.
- Ratings based on maximum engine speed of 3000 rpm.
- Ratings based on standard engine. Please consult factory for ratings with low emissions engine.
- Ratings must be determined with partially open slide valve so as not to exceed maximum engine horsepower. Please consult the factory.
- For high stage, ratings based on 0°F suction superheat and 10°F liquid subcooling at the condenser.
- Fuel (MBH) = natural gas fuel consumption based on higher heating value of 1020 Btu/scf.
- HER (MBH) = engine heat recovery only. Optional exhaust heat recovery available.
- All specifications are ±5% and subject to change without notice.
- Consult your TecoFROST representative for a customized output of your design conditions.